

Patio Cover Kits

Instruction Manual

Free Standing

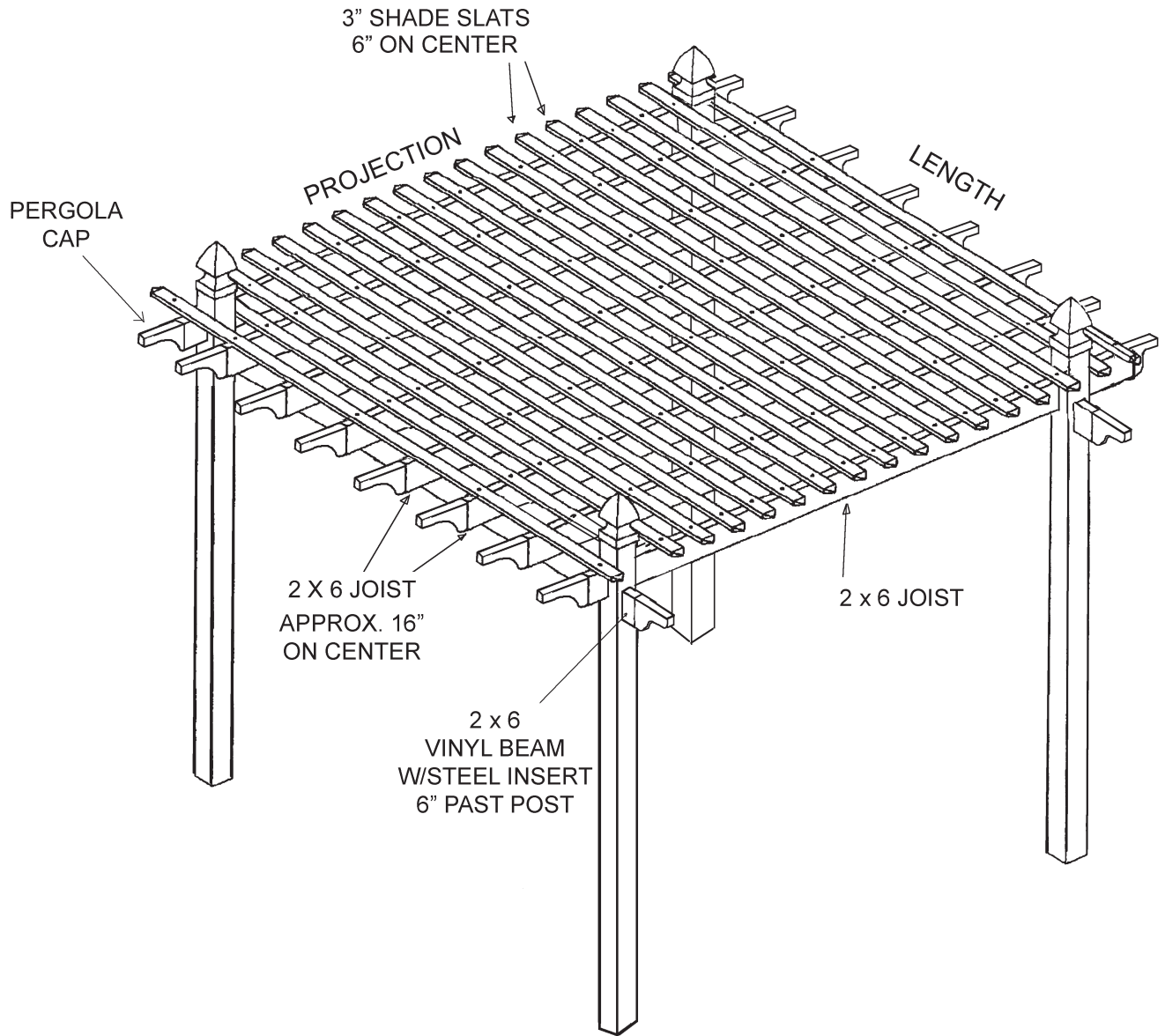

FREE STANDING

STEP-BY-STEP INSTRUCTION PROCEDURES

COMPONENTS	1
TOOLS NEEDED	1
INTRODUCTION	2
PERGOLA LAYOUT	3
LAYOUT OF THE SUPPORT POST	3
INSTALLING SUPPORT POST	4
INSTALLING POST BASES	6
INSTALLATION OF SUPPORT POST FOR CONCRETE PATIOS & DECKS	9
INSTALLATION OF 2" X 6" SUPPORT BEAM	10
INSTALLATION OF JOIST AND JOIST BEAM BRACKETS	11
INSTALLATION OF JOIST	12
INSTALLING 3" SHADE SLATS	13
INSTALLATION OF EXTERNAL COMPONENTS	13

Fasteners and Hardware Provided:

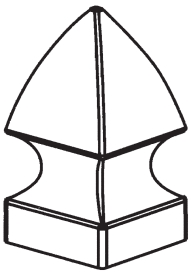

5" Post Cap

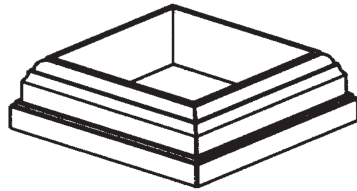

Decorative Post Base Ring (For Concrete & Wood Patios)



2" x 6" Pergola Cap



2" x 6" Joist Hanger Brackets

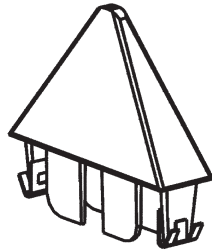

Shade Slat Picket End

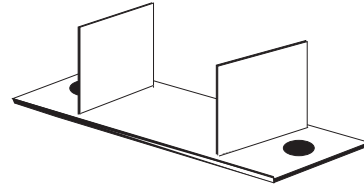

Joist Beam Bracket



Vinyl Glue

Vinyl Glue



5" Ledger Lock Screw

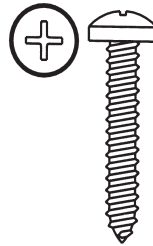

1 1/2" Self Tapping Screw (For Joist Beam Brackets & Joist Hanger Brackets)

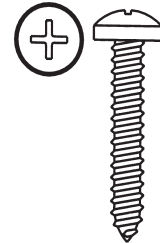

1 1/2" Self Tapping Screw (For Shade Slats)

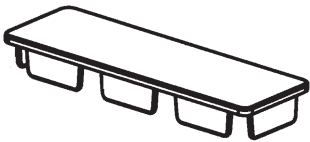

2" x 6" End Cap



Cap For 5" Ledger Lock Screw

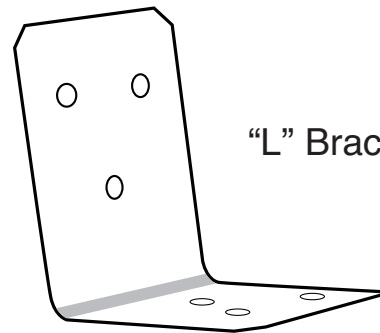

"L" Bracket

Tools Required:

- Tape Measure
- Framing Level
- Framing Square
- Circular Saw (Fine Tooth Blade)
- Drill and Drill Bits
- 1/2" Masonry Bit (Concrete Patios)
- 1/2" Wood Bit (Wood Decks)
- 1/8" Drill Bit (Pre-drill holes for Joist Beam Brackets)

- Framing Square (Patios Attached To House)
- (2) Step Ladders
- String Line or Chalk Line
- Crescent Wrench (Concrete and Wood Patios)
- Hammer
- 80 lb. Ready Mix Concrete
(Pergolas installed in ground)

PERGOLA

FREE STANDING

Thank you for purchasing your new pergola from VinylPatioKits.com. We have spent numerous hours in developing an installation manual which we hope will provide simple and concise instructions to help you build a beautiful new addition to your back yard. Enjoy!

This instruction booklet will provide a step-by-step process for installing your new pergola. Should you decide to modify the dimensions of your pergola from the standard kit size, a circular saw with a sharp fine-tooth blade is all that is needed to cut, shorten or modify the vinyl components on your pergola.

Please read these instructions thoroughly prior to the construction of your pergola.

DETERMINING PERGOLA HEIGHTS AND LAYOUT

The average height of a pergola is 8', measured from the ground level to the bottom of your support beam.

The height of your pergola will be based on several factors. For example, the height may be determined by the height of the roof line on single-story homes, or the heights of existing doors and windows.

Layout of your pergola is just as important as height. You will need to consider post location, slope of concrete patios and wood decks and sprinkler or utility lines if it is an in-ground pergola.

Note: It is recommended to verify local building codes, ordinances, neighborhood covenants, or height restrictions regarding this type of structure and heights.

PERGOLA LAYOUT

PROJECTION AND LENGTH

On our standard kits, the maximum projection distance is 14'. Projection is the distance from the outside of the post to the outside of the next post, running in direction of the joists (See Diagram 1).

On "attached" pergolas the projection is distance from the attachment point on the house to the outside of post.

The length of your pergola is measured from outside edge of the support post. Length is also the direction your support beam runs. Length of a pergola is unlimited. With maximum spans between posts of 14', you can have several posts in the length of your pergola, if the length exceeds 14'.

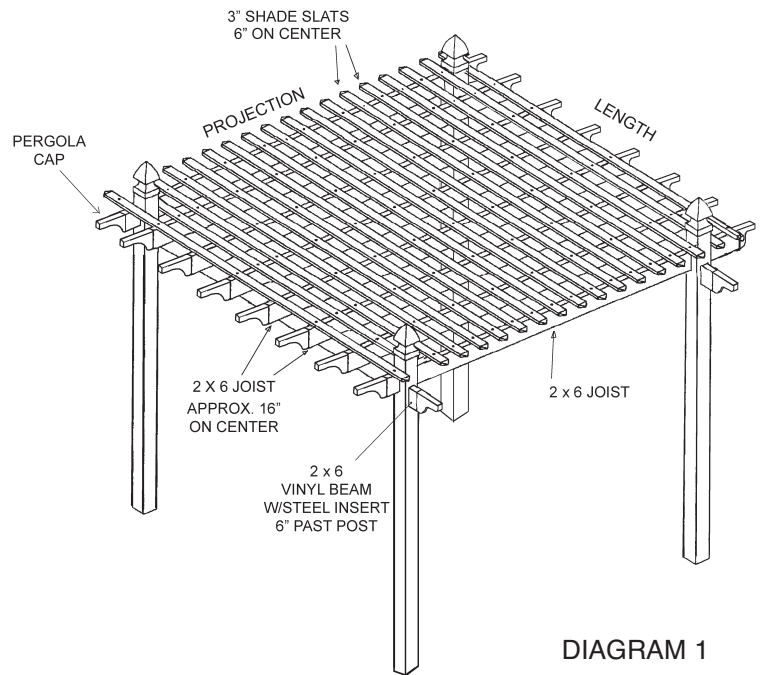

DIAGRAM 1

LAYOUT OF THE SUPPORT POST

Post location is the most important part of the installation process. Take your time measuring and analyzing window and door heights, location of electrical and phone lines, etc., prior to the layout of your post.

Note: *The patio cover you order will be based on the measurements from outside edge to outside edge of the posts in both the projection and length.*

STEP 1

Measure and temporarily mark the projection and length of the pergola (See Diagram 2 and 2A).

FREE STANDING

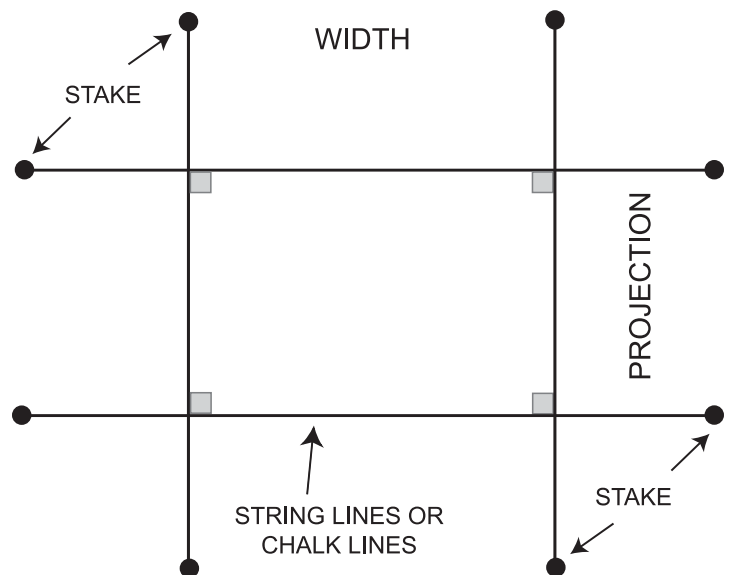
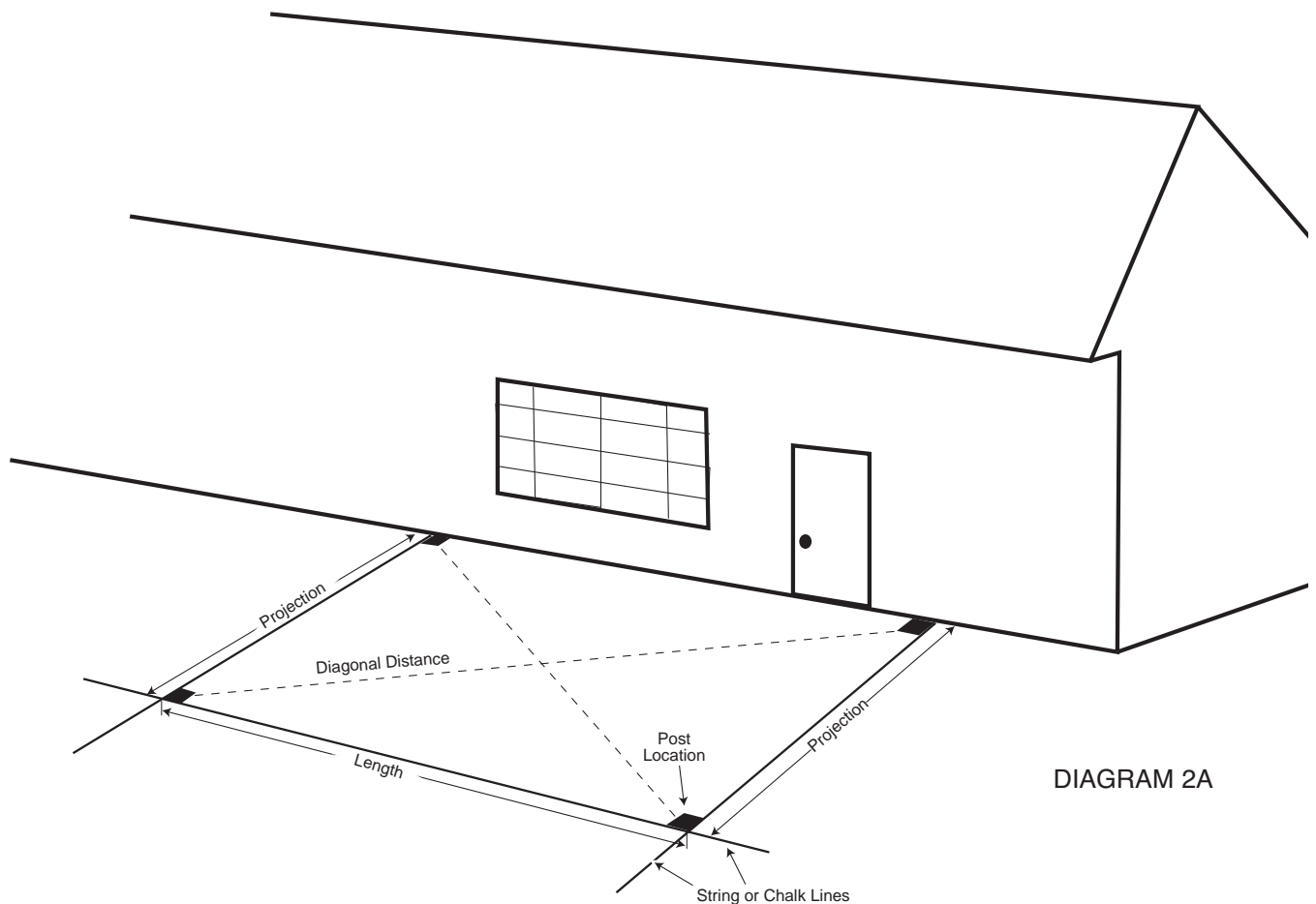

DIAGRAM 2



STEP 2

Using string lines or chalk lines layout the pergola dimensions. Measure the diagonal distance from corner to corner (See Diagram 2A). Diagonal distances must be the same to ensure a square installation. Adjust the lines until the diagonal distances are square. The inside corner of the string lines will be the post location.

INSTALLING SUPPORT POSTS

Pergolas can be installed in the ground, on concrete patios or wood decks.

IN GROUND CONSTRUCTION

Pergolas installed in the ground require different installation procedures than concrete patios and decks.

STEP 1: DIGGING HOLES

After you have determined where the posts will be located, you are now ready to dig each post hole. Post holes (piers) are dug 12" in diameter and 30" deep (See Diagram 3).

STEP 2

After all holes are dug and cleaned, place a post into a hole, level and measure the post height to determine the amount of excess post which will be cut from the bottom. The recommended height of the pergola is 8' from the ground level to the bottom of the support beam (See Diagram 4).

Note: The depth of the hole and slope of the ground (if any) will affect the post length prior to installation. Not all posts will be cut to the same measurements.

Note: Heights of windows, roof overhangs, or other factors may change the recommended height. Make sure you calculate heights and distances before cutting off any excess post.

STEP 3: CONCRETING POST

With the first post cut to exact height,

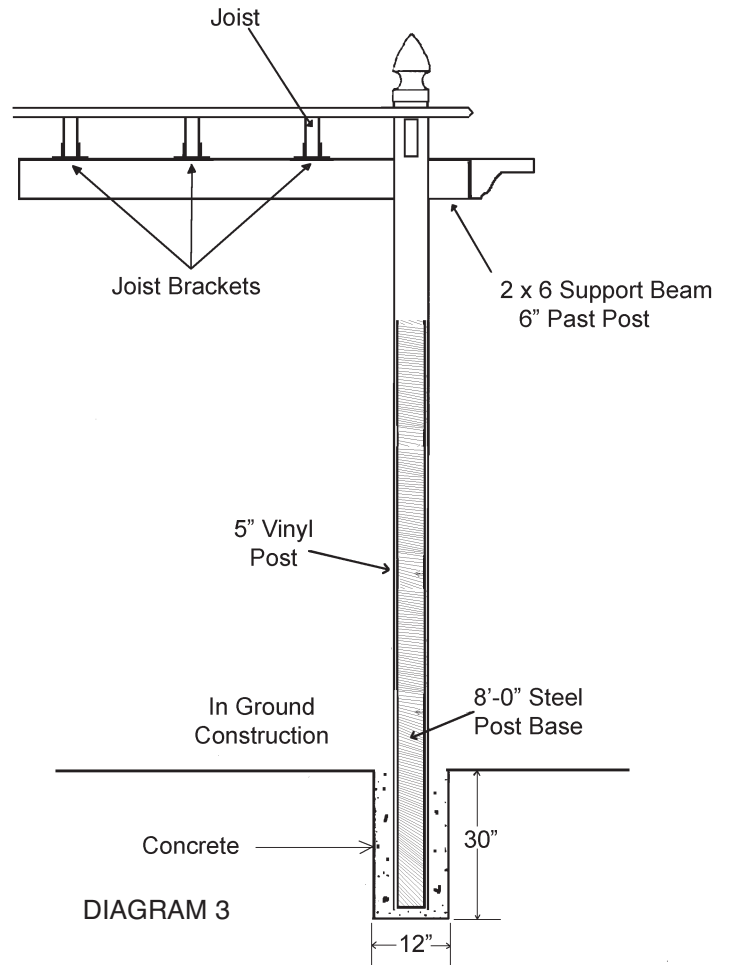
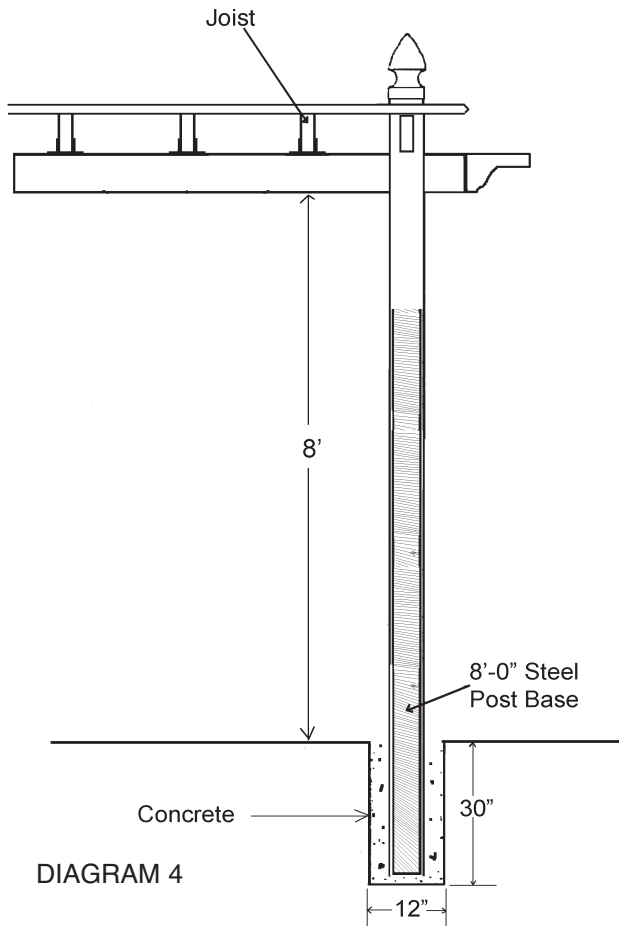

insert the 8' galvanized steel post base inside the bottom of the 5"x5" support post, place the post with the insert down into the hole and add ready mix concrete all the way to the top. Check to make sure the slots in the holes are facing the correct position to accept the support beams. Level the post and smooth off top of concrete. Let your concrete set up for at least 48 hours prior to installing your support beams.

Note: The best way to mix your concrete is in a wheelbarrow. Do not make the mixture too soupy. This will affect the concrete strength and cause the concrete to be brittle in time. A thick sludge is ideal, plus it will hold the post in place while concrete is setting up.

STEP 4

Go to the opposite hole, place a post into the hole. With the help of another person, place a 2x6 support beam up against the first post where the beam is even with the support beam hole and up against the other post.

STEP 5

With both post and support beam leveled (using a framing level), make a mark on the side of the post where the top of the beam is level with the post (See Diagrams 5 and 8).

STEP 6

Cut off your excess post, and insert the 8' post base and concrete this post. Once you have concreted the post, check for levelness again.

STEP 7

Repeat steps 2 through 7 for the other outside posts.

Note: *The post base ring can be installed on the post before or after the posts are installed.*

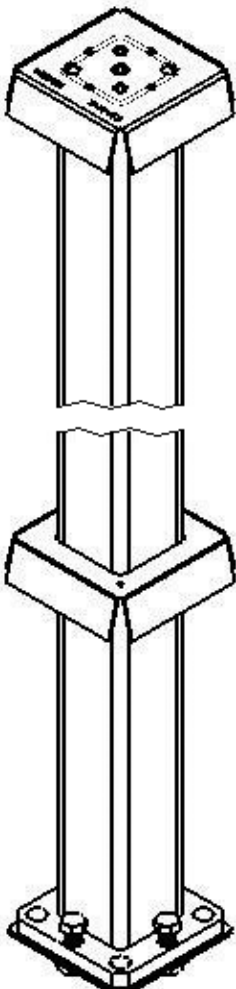
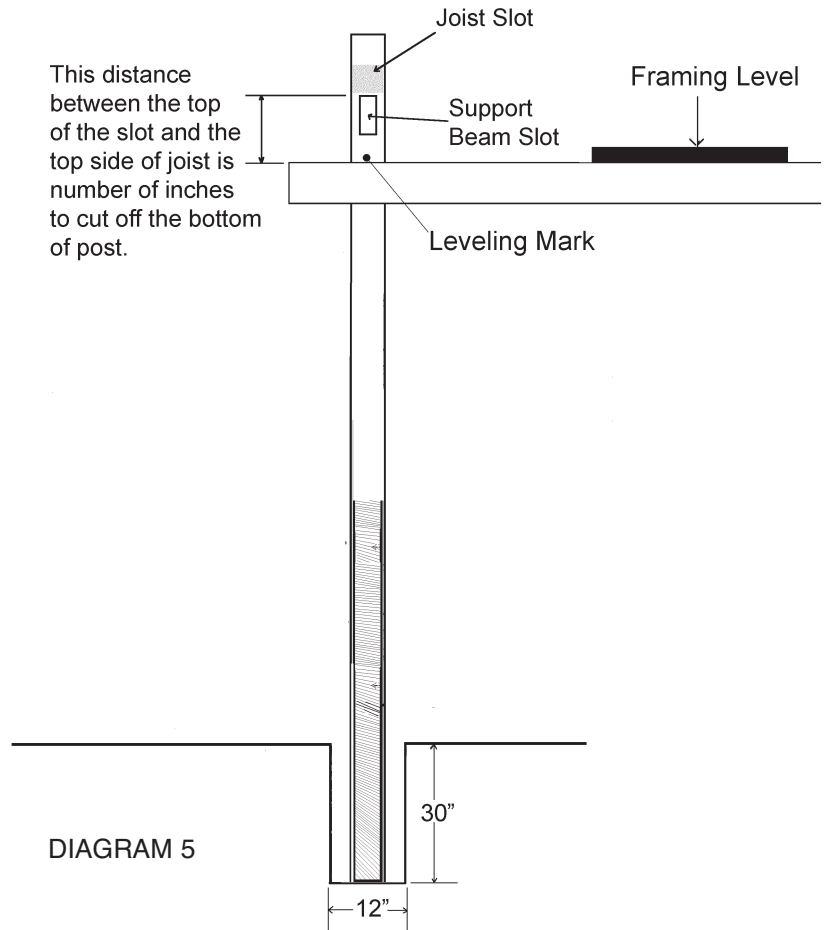
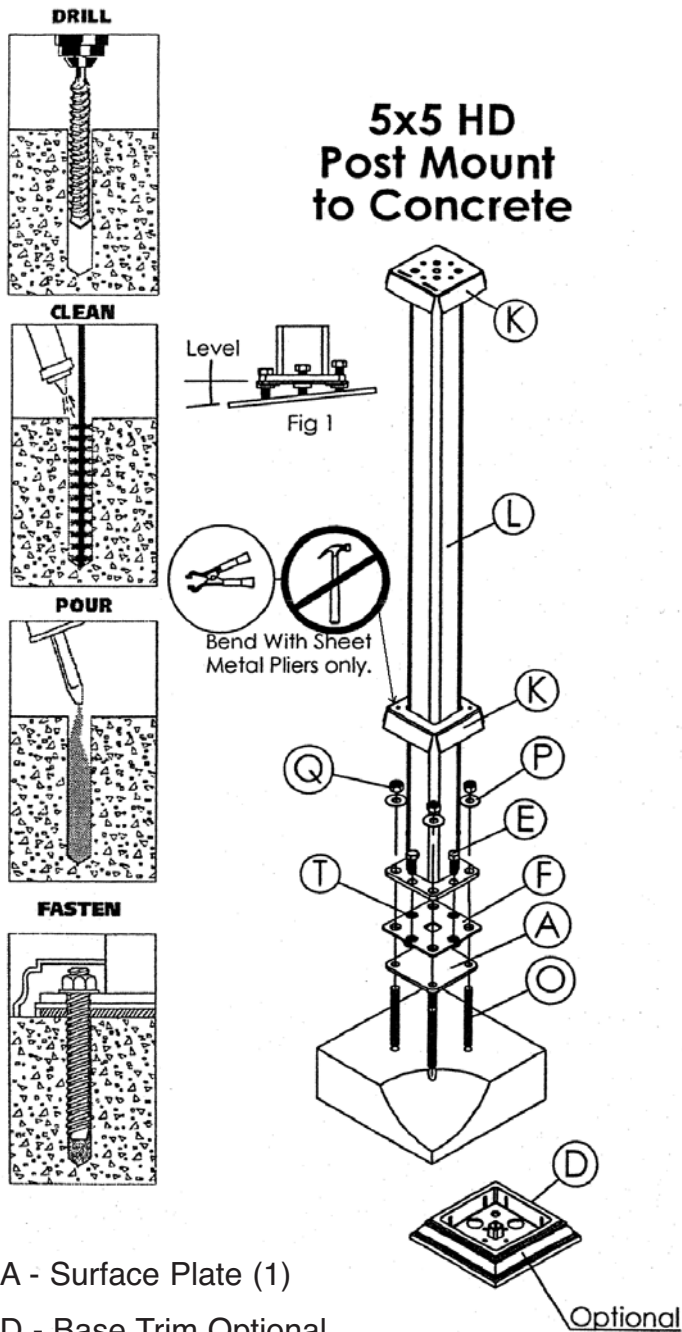

DIAGRAM 6

INSTALLING POST BASES ON CONCRETE PATIOS

After you have determined where each post will be located on your concrete patio, you are ready to install 36" galvanized steel post bases (See Diagram 6 and 6A).



- A - Surface Plate (1)
- D - Base Trim Optional
- E - 5/16" x 1" Leveling Bolts (4)
- F - Leveling Insert (1)
- K - Post Stabilizer (2)
- L - 2x2 Square Tubing (1)
- O - 3/8" x 4-1/2" Threaded Rod (4)
- P - 3/8" Washers (4)
- Q - 3/8" Nuts (4)
- T - 5/16" Leveling Insert Nuts (4)

DIAGRAM 6A

Note: You will determine where to cut off excess post for proper height once post bases are secured (See: INSTALLATION OF SUPPORT POST on page 9).

- 1) Layout the locations for the post.
 - 2) Take surface plate (A) and use as a template, mark the four corner holes for the (4) 3/8" x 4-1/2" threaded rod (O).
 - 3) Drill the marked holes using a 7/16" masonry drill bit. Drill the hole into the concrete surface to a depth of 3-1/2". Thoroughly clean the holes of dust and debris.
 - 4) It is recommended to use chemical anchoring epoxy (epoxy not included) with threaded rod (O) per ASTM standards.
- *For information regarding chemical anchoring contact: Powers Fasteners at 800-524-3244.
- 5) Align the surface plate (A) over the threaded rods(O).
 - 6) Position the optional base trim (D) over the top of the surface plate (A).
 - 7) Take leveling insert (F) and (4) 5/16" nuts (T). Press nuts into hex shapes of leveling insert (F). Align over holes of optional base trim (D) and surface plate (A)
 - 8) Take the post mount and place it into the optional base trim (D) and over the threaded rods (O).
 - 9) Take four washers (P) and place one on each threaded rod (O), then put nuts (Q) on threaded rod (O). Hand tighten nuts (Q) to allow leveling of the post.
 - 10) Screw the (4) 5/16 x 1" leveling bolts (E) into the (4) 5/16" nuts pressed into leveling plate (F). Adjust the leveling bolts (E) to straighten the post. (See Figure 1) After post has been leveled, tighten nuts (Q). (Do not over tighten)
 - 11) Slide vinyl support post over the post mount until it seats into the optional base trim (D) or meets the deck surface. The post stabilizers (K) will secure the post into its proper position.

INSTALLING POST BASES ON WOOD DECKS

After you have determined where each post will be located on your wood deck, you are ready to install the 36" galvanized steel post bases (See Diagram 6B).

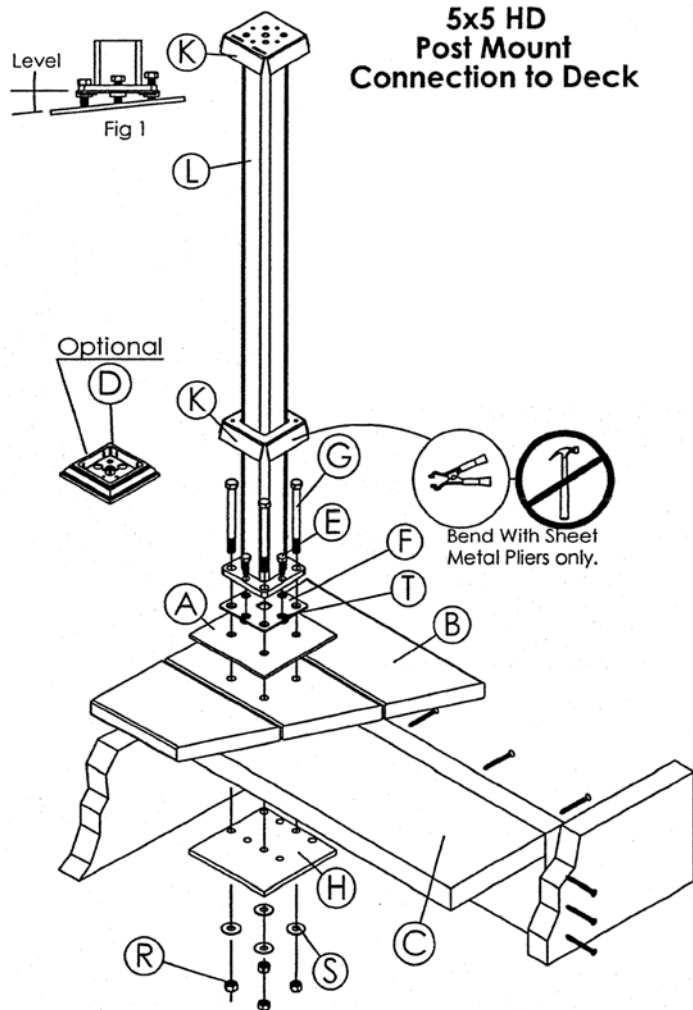

- A - Surface Plate (1)
- B - Deck Board Example
- C - Reinforcement Board Example
- D - Base Trim (Optional)
- E - 5/16" x 1" Leveling Bolts (4)
- F - Leveling Insert (1)
- G - 3/8 x 4-1/2" Bolts (4)
- H - Bottom Plate (1)
- K - Post Stabilizer (2)
- L - 2 x 2 Square Tubing (1)
- R - 3/8" Nuts (4)
- S - 3/8" Washers (4)
- T - 5/16 Leveling Insert Nuts (4)

DIAGRAM 6B

- 1) Layout the locations for the post.
- 2) Take surface plate (A) and use as a template, mark the four corner holes.
- 3) Thickness of wood deck and reinforcement board underneath deck should be a minimum 2-1/2".
- 4) Drill four 7/16" holes through the marked holes, drilling through the deck board (B) and the reinforcement board (C).
- 5) Align the surface plate (A) over the drilled holes.
- 6) Position the optional base trim (D) over the top of the surface plate.
- 7) Take leveling insert (F) and (4) 5/16" nuts (T). Press nuts into hex shapes of leveling insert (F). Align over holes of optional base trim (D) and surface plate (A)
- 8) Take the post mount and place it into the optional base trim (D) lining up the holes.
- 9) Next insert the (4) 5/16" x 4-1/2" bolts (G) into the drilled 7/16" holes.
- 10) Take bottom plate (H) and line up with bolts under the deck as shown in diagram. Add (4) washers (S) and (4) nuts (R). Hand tighten nuts (R) to allow leveling of the post.
- 11) Screw the (4) 5/16 x 1" leveling bolts (E) into the (4) 5/16" nuts pressed into leveling plate (F). Adjust the leveling bolts (E) to straighten the post. (See Figure 1) After post has been leveled, tighten nuts (R). (Do not over tighten)
- 12) Slide vinyl support post over the post mount until it seats into the optional base trim (D) or meets the deck surface. The post stabilizers (K) will secure the post into its proper position.

Note: You will determine where to cut off excess post for proper height once post bases are secured (See: *INSTALLATION OF SUPPORT POST* on page 9).

INSTALLATION OF SUPPORT POST FOR CONCRETE PATIOS AND DECKS

STEP 1

With the post bases secured, place the vinyl support posts over the post bases. Use a 2"x6" (hollow) joist and place up against the outside of each post at a distance of 8' from the ground level to the bottom of the 2"x6" joist (See Diagram 8).

Note: 8' is the recommended height of the pergola from the ground level to the bottom side of the support beam. Due to heights of windows, roof overhangs, or other factors, heights may vary. Make sure you calculate heights and distances before cutting off any excess post.

STEP 2

With the joist and posts both leveled, make a mark on the post at the top of the 2"x6".

STEP 3

The distance between this mark and top of the support beam slot is the amount of post you will need to cut off (the bottom slot is for support beam, top slot is for the joist to extend through) (See Diagram 8).

STEP 4

With the post cut to exact measurements, place your decorative post base ring over the post base.

STEP 5

Slide the support post over the post base and down into the post base ring (both will snap in place).

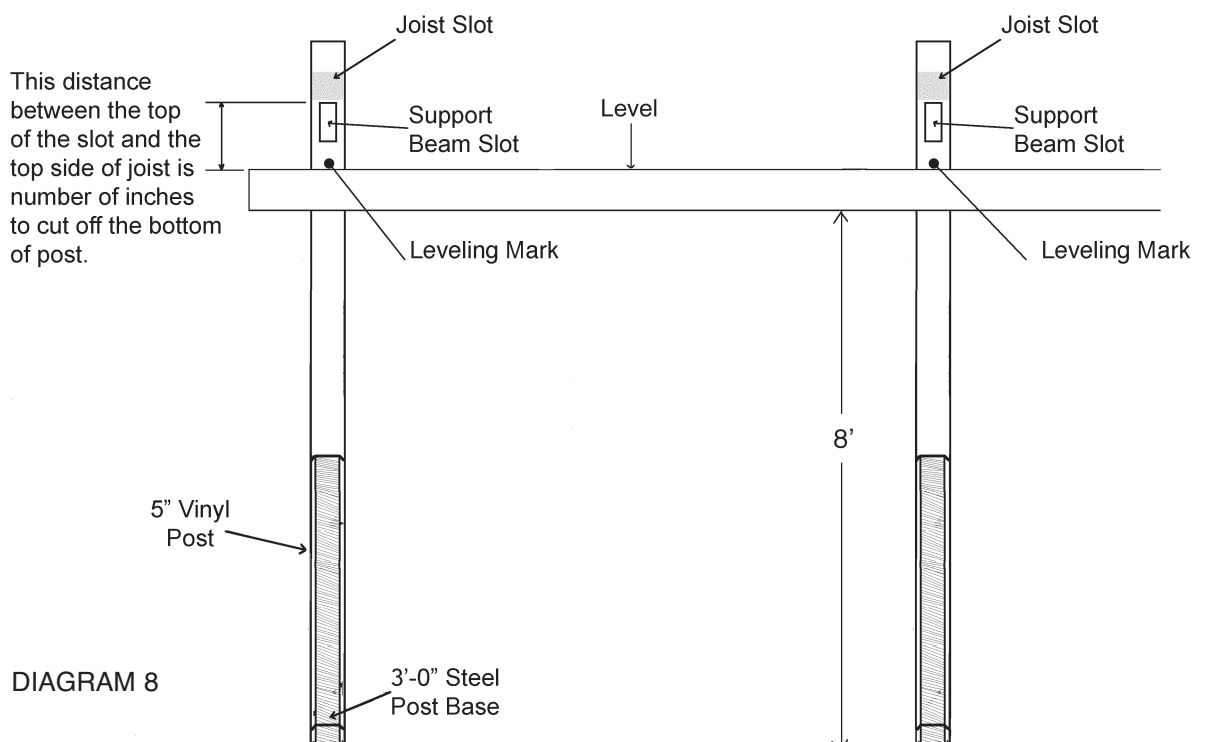

Note: Before you cut off post on the other support beam side you need to make sure the joists will be level when they extend over the support beams. Sometimes a concrete patio or wood deck is not level and without making adjustments on your post heights your pergola will be at a slight angle. To check to see if your patio or deck is level, place a large contractors level on the surface of the patio or deck.

INSTALLATION OF 2"x 6" SUPPORT BEAM

The support beam will consist of a 2"x6" vinyl hollow beam and galvanized steel insert.

The inserts come in two pieces if the beam length is greater than 9'. The two-piece inserts telescope into each other in order to extend to the proper length inside the vinyl beam. Make sure that these inserts extend the full length of the beam. Sometimes in shipment they slip inside each other and you will have to re-adjust the length.

STEP 1

Support beams extend 6" past the outside edge of the outside support posts (See Diagram 9).

STEP 2

Slide the vinyl beam (with inserts inside) through both holes of the 5" post and through both holes of the other 5" post. Install Pergola "L" brackets for the beam (See Diagram 9).

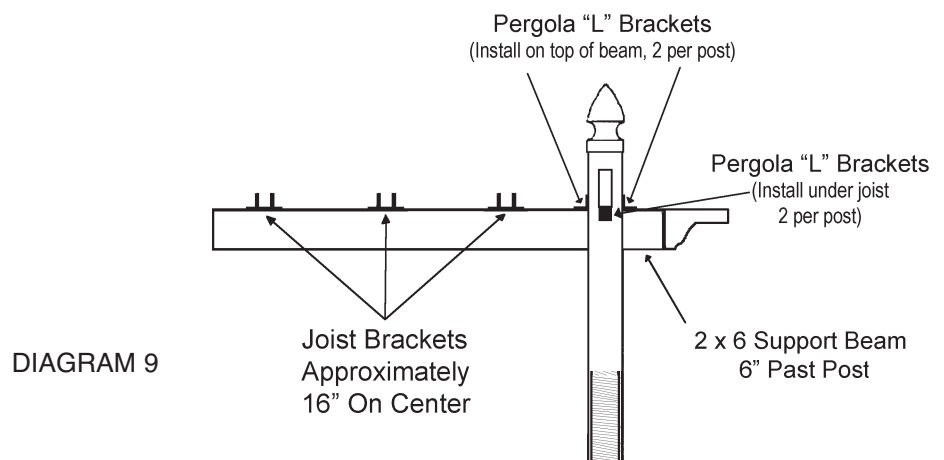

Note: With length spans greater than 15', you will have additional support posts to support beams. If this is the case, you will have a two piece beam. If you do have a two piece beam, make sure they are spliced in the middle of the post (See Diagram 10).

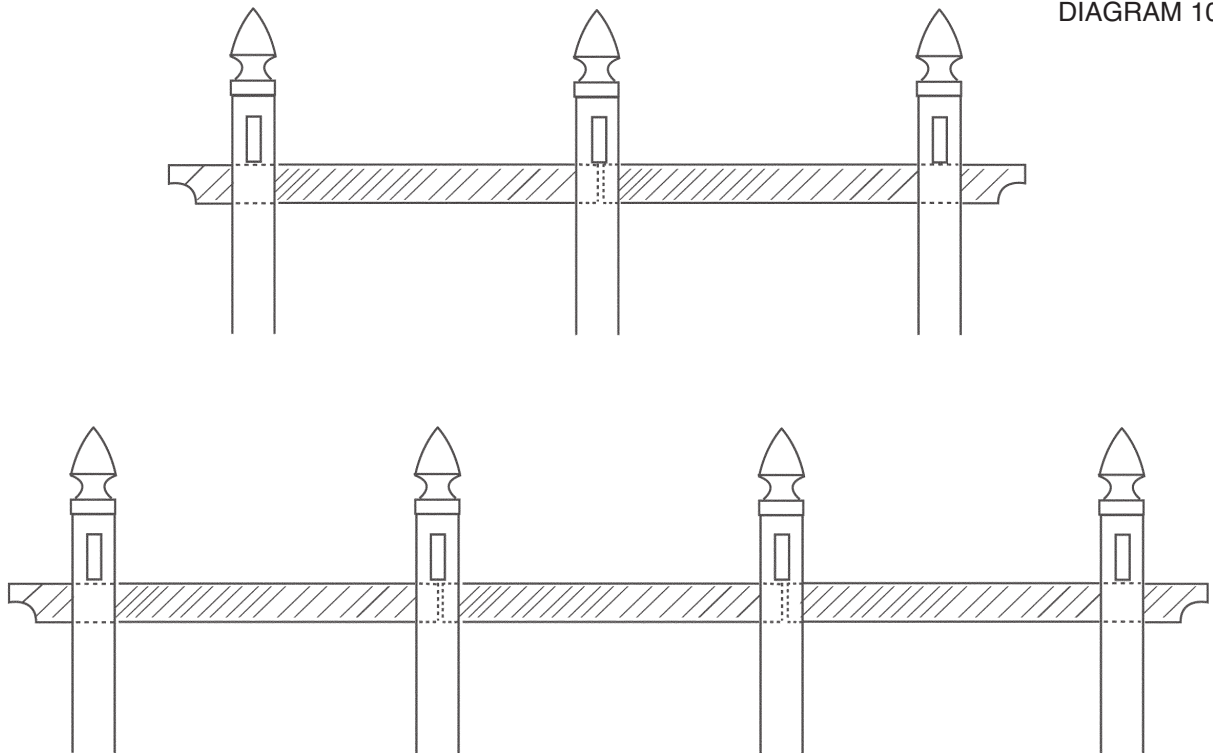

INSTALLATION OF JOIST AND JOIST BEAM BRACKETS

The 2"x6" joists come in lengths longer the projection of the pergola. Joists are cut to extend a minimum of 6" past the outside edge of the post.

STEP 1

Insert a 2"x6" joist through each top slot on the support post. These joists are the primary joists. Install Pergola "L" brackets under the joist (See Diagram 9).

Note: With the primary joist in place, you will need to find appropriate spacing for the joist beam brackets on the support beam and mark where each bracket will be installed.

The number of joists provided in your kit is calculated based on the length of your pergola. The joist brackets and joist hangers need to be installed approximately every 16" on center, starting from the center of each post. Your goal is that when you look up at the pergola, the spacing of the joist looks even to the eye.

STEP 2

Install each joist beam bracket with two 1 1/2" white self-tapping screws, screwing into the vinyl sleeve and steel insert(s). Pre-drilling the holes will make it easier when you prepare to install the brackets, especially if you are going through two layers of steel insert.

DIAGRAM 11

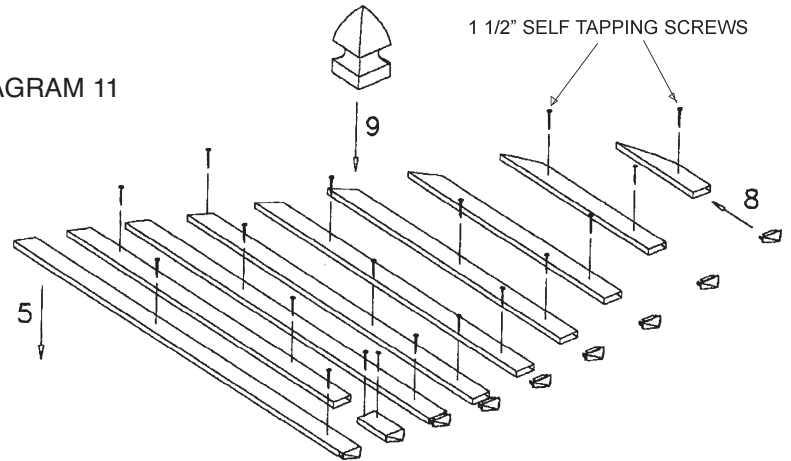

STEP 3

Install the joist brackets on the other beam using the same measurements as you did on the first support beam.

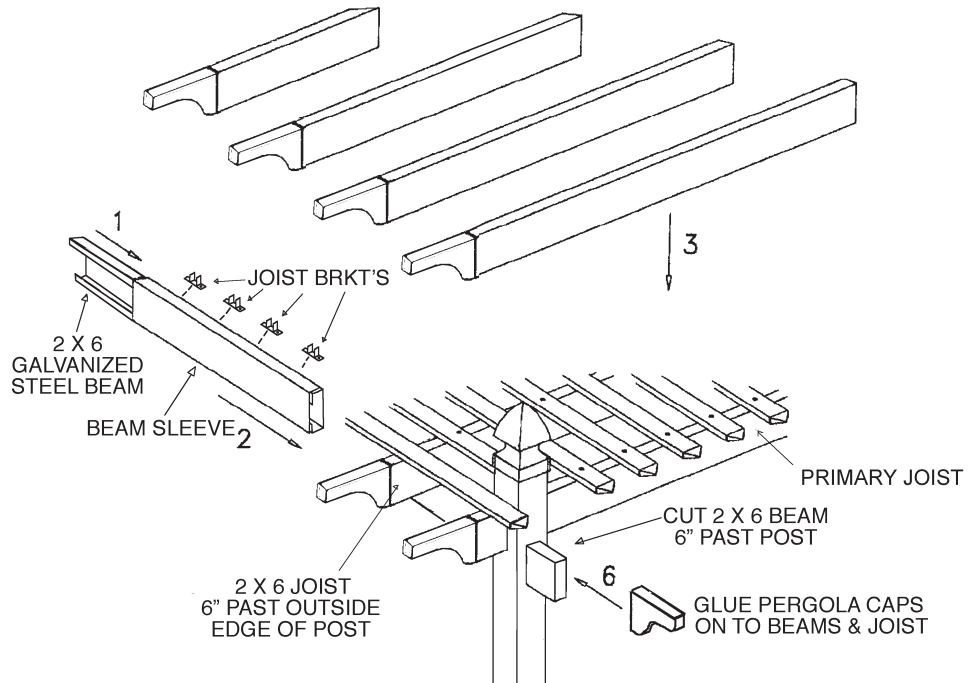

INSTALLATION OF JOIST

You are now ready to install the 2"x6" joists.

STEP 1

Place the joist in the front and rear joist beam brackets.

STEP 2

Secure the joist to the brackets by screwing one 1 1/2" white self-tapping screw on each side of the bracket.

STEP 3

Repeat steps 1 through 4 on all remaining joists.

INSTALLING 3” SHADE SLATS

The 3” shade slats are cut to extend 6” further than your pergola length. Your kit will contain enough shade slats for adequate coverage using a 3” gap between slats.

On pergola lengths over 15’ splicing will be required. Additional slat material will be included to allow a splice in the middle of a 2”x6” joist. On lengths greater than the 15’ all slats will need to be custom cut. Allow for a minimum of 6” overhang past the outside 2”x6” joist.

STEP 1

Install slats on both sides of support posts using one 1 1/2” self-tapping screw (use tan snap caps with tan pergolas) per joist. Be careful not to over-tighten screw.

STEP 2

Using a 3” slat as a template, mark slat locations working from the support post towards the building. As you approach the last four or five rows, you want to adjust your marks to achieve as close to a 3” gap as possible. (For example, in the last four rows you may have a gap which is more or less than 3”.) Your goal is to have the slats look visually good to the eye when looking up at the pergola.

Note: The number of slats that come with your kit is based on no less than a 3” gap.

STEP 3

Install 3” slats working from the building back towards the support posts.

Important: Before installing the first slat at the house, confirm proper slat placement to achieve slat spacing.

INSTALLATION OF EXTERNAL COMPONENTS

The last installation required is installing the post caps, pergola caps, ledger lock caps, ledger end caps and shade slat pickets.

STEP 1

With the vinyl glue that comes with the kit, apply a small dab of glue on each component and install the pieces listed above. Do not apply glue on total surface area if for some reason you want to remove these pieces at a later date.